



TESS402 DATASHEET

EXTERNAL TRAPEZOIDAL TENSION SYSTEM

Bespoke shapes to meet your requirements. Any angle, any direction, anywhere.

Modern glazing design is anything but square. For special shapes including domes and tapered windows, the TESS 402 provides an adaptable solution. Relieving rollers allow the blind to follow the direction of the curve whilst ultra-thin tension cables maintain fabric tension. Unlimited colour finishes and a wide range of fabrics make it suitable for any project. Our single barrel mechanism keeps the fabric constantly under tension and produces a smooth, quiet travel.

- Protective headbox
- Single barrel system
- Trapezoidal or uneven shapes
- Domes, angles and curves
- Reliable and robust

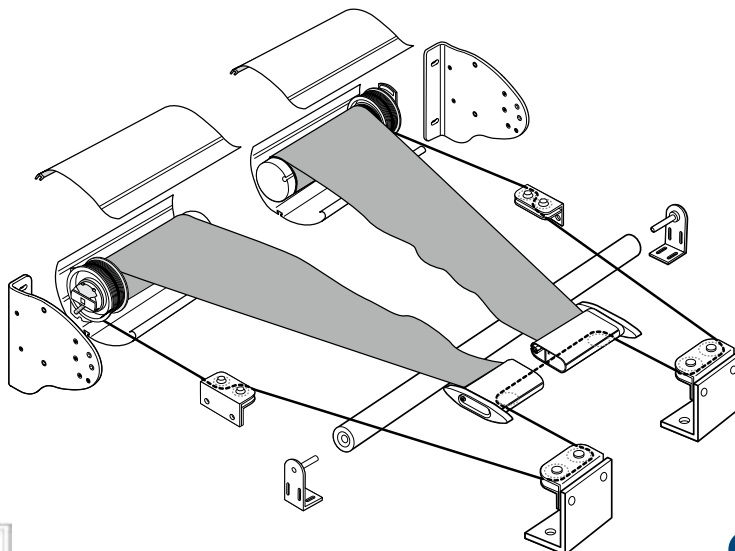

Guthrie Douglas

BACK FIX

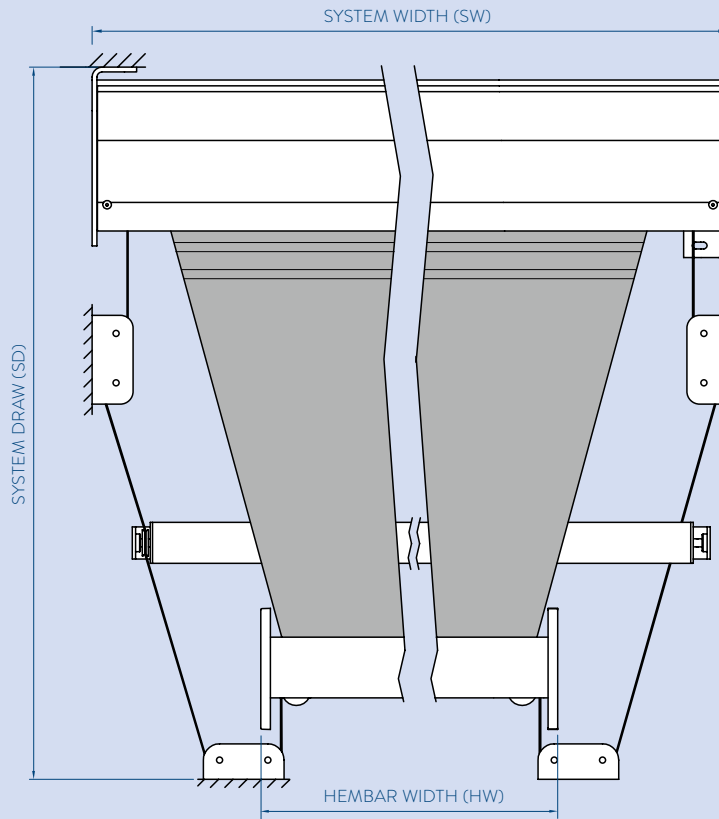
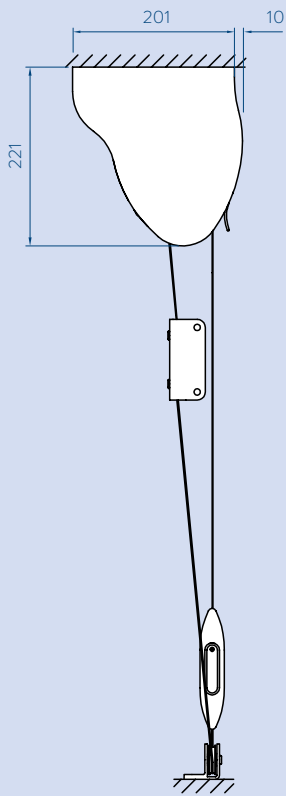

BOTTOM FIX

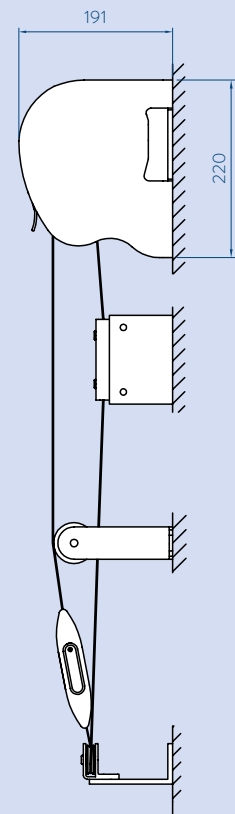

KEY FACTS

Typical use	Flat, curved or sloped glazing
Shape	Trapezoidal
Running direction	Any
Guides	None
Width	870 mm - 4000 mm
Draw	≤6500 mm
Fabric area	≤16 m ²
Brackets	Aluminium
Relieving rollers	Aluminium
Finish	RAL Powder coat
Installation options	Bottom, back

TECHNICAL INFO

Fabric tension	>100 N
Weight exc. fabric	~12.5 kg + 10.2 kg/m width
Fixing load	≤36 kg per bracket
Operating temp.	0 to 55 °C
Motor	15 Nm, 17 rpm
Electrical	230 V, 50 Hz, 140 W, 0.65A
	120 V, 60 Hz, 130 W, 1.1A
Max run time	4 min
Fabric speed	~5 m/min
Controls	Radio, Wired

