

# 6

## GB Re-inforcements

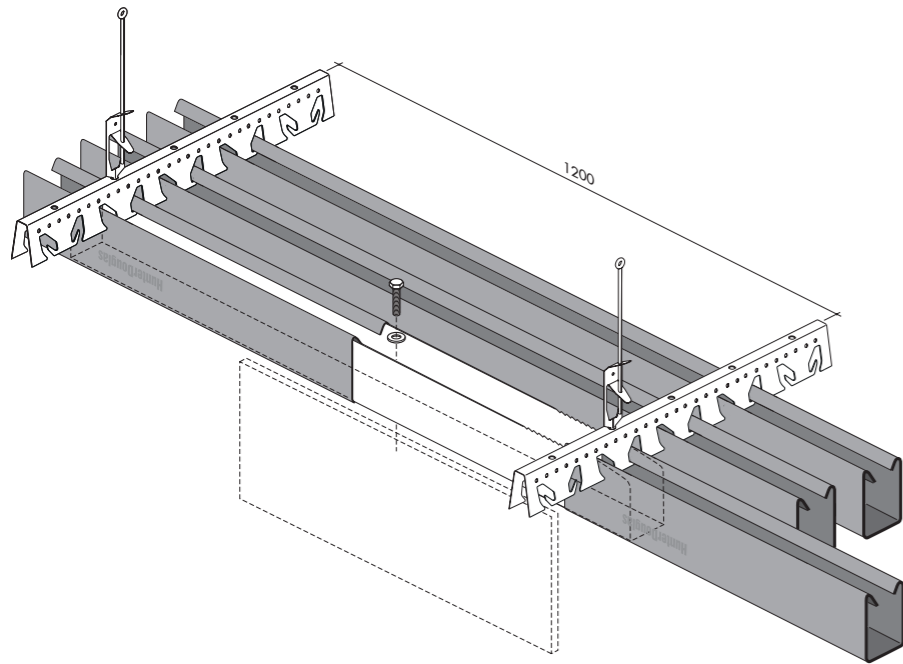

# 7

## GB Demounting

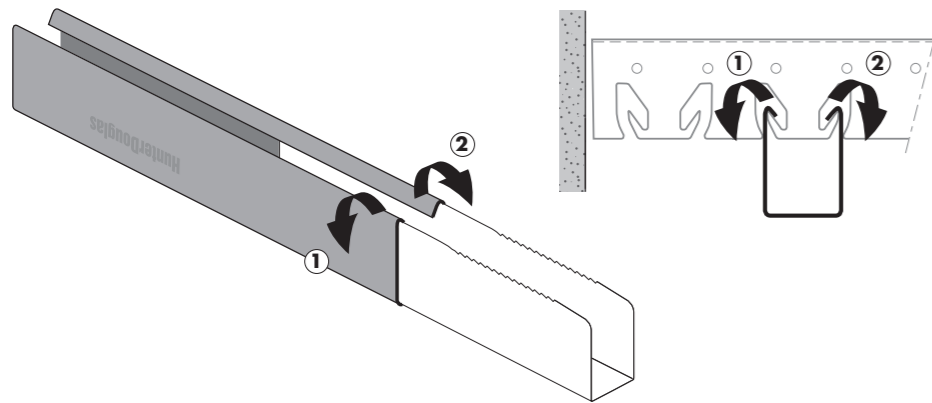

**GB** While demounting the panel make sure to support the part of the panel that has already been removed from the carriers.



## GB Maintenance

**GB** Hunter Douglas HeartFelt® ceilings are, by utilising high quality materials easy to maintain. When cleaning is required, it is advised to use a feather duster. A mild vacuum cleaning may be used if necessary. Never use wet cleaning agents. Before cleaning the ceiling, always try the chosen method of cleaning on a non-visible part of the panel.

## HeartFelt® Linear Panel 1

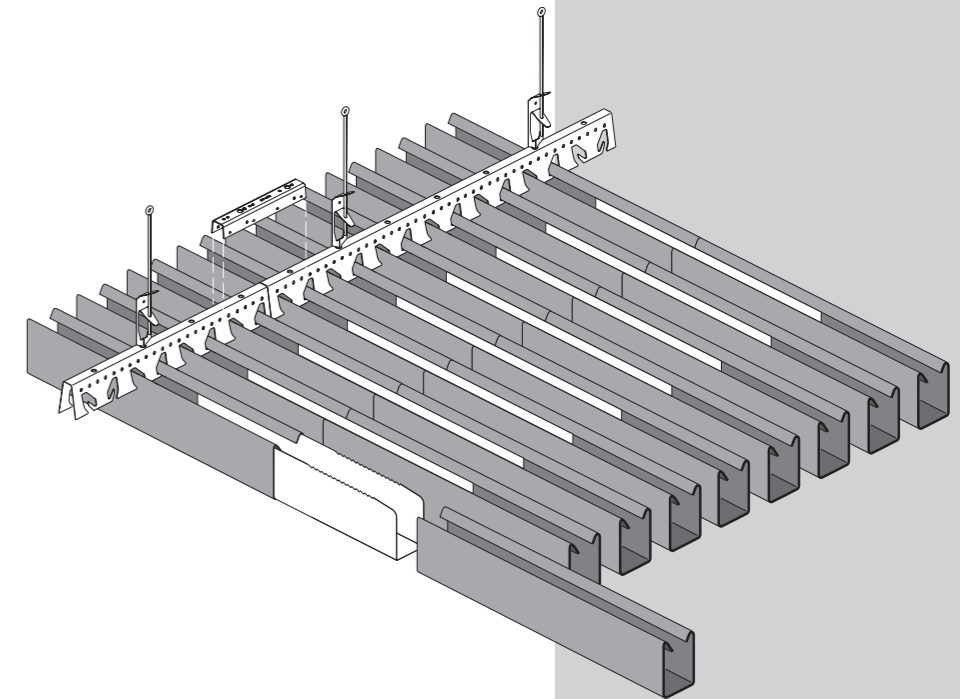

## GB Installation instruction

We have endeavoured to design these instructions to assist a trained ceiling professional with the mounting and installation of a Hunter Douglas HeartFelt® ceiling. We accept no responsibility for poor workmanship, failure to comply with these instructions, improper installation or installation by someone other than a trained ceiling professional.

**HunterDouglas**

[www.hunterdouglascontract.com](http://www.hunterdouglascontract.com)

revision 2

**HunterDouglas**

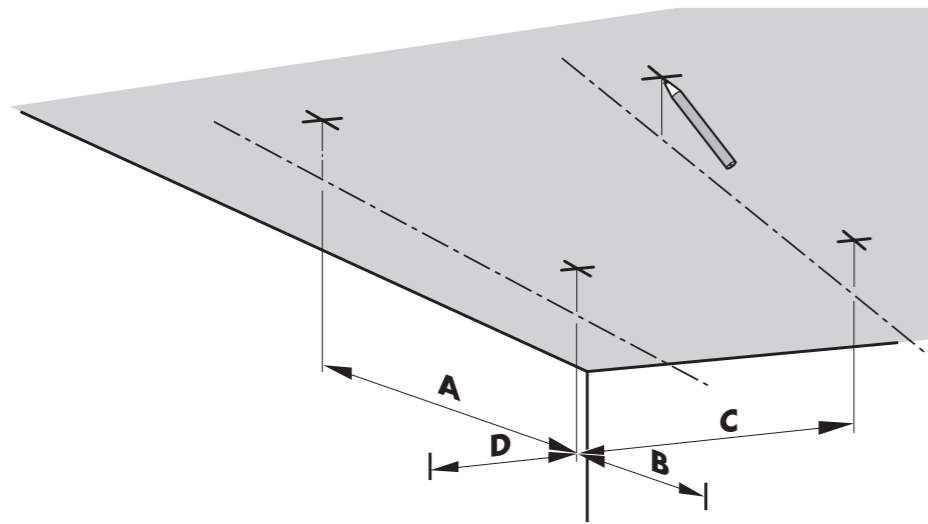
**1****GB** Marking suspension points

Panel type	Max. carrier span		Max. panel span	
	A	B	C	D
Panel 1	1500	300	1200	150

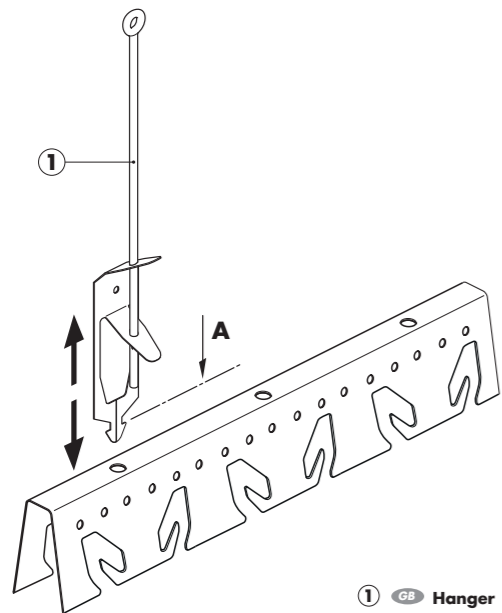
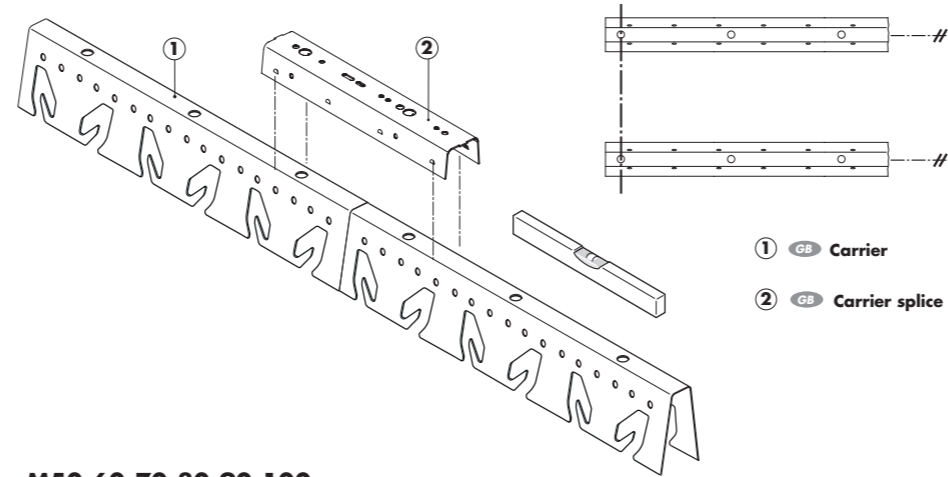
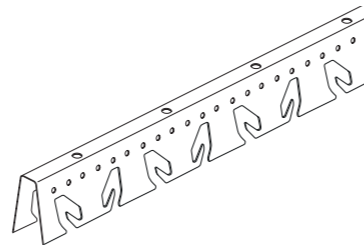
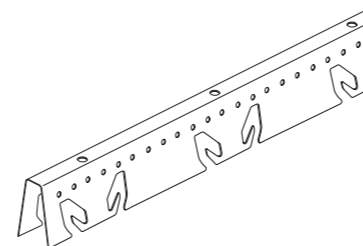
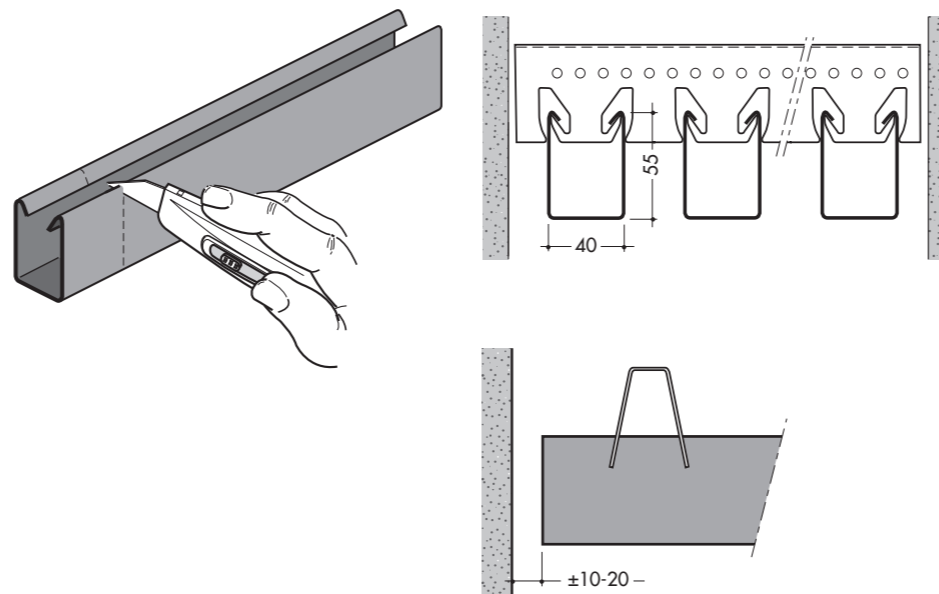
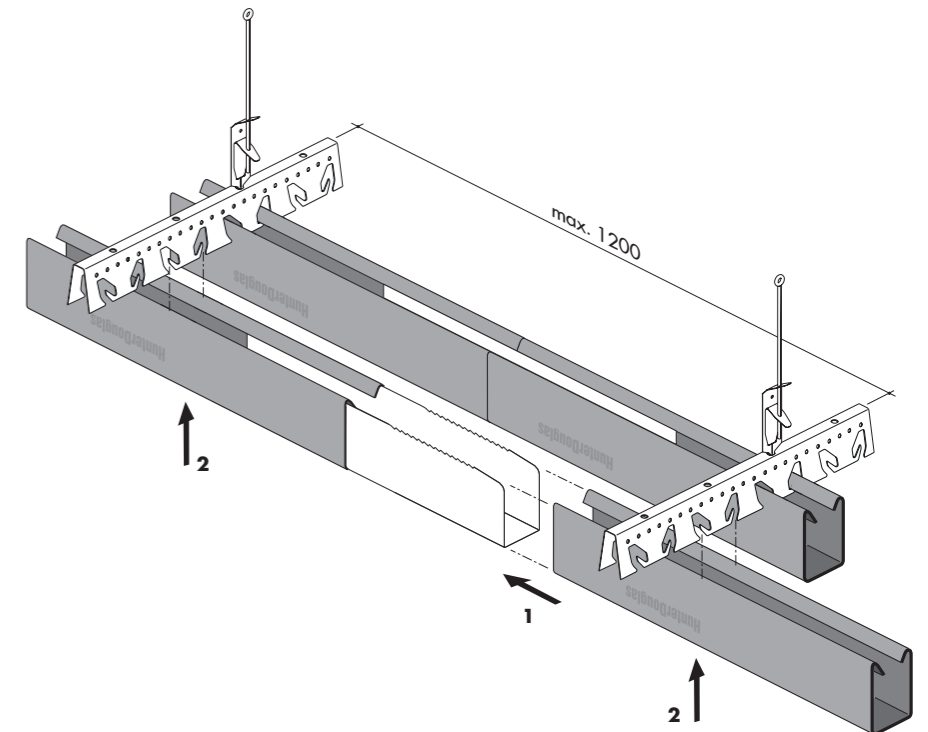
**2****GB** Installing the hangers**1** **GB** Hanger**A** **GB** Height reference**3****GB** Installing the carriers**1** **GB** Carrier**2** **GB** Carrier splice**M50-60-70-80-90-100****Carrier M50****Carrier M80****4****GB** Installing the adaptor panels**5****GB** Installing the panels**GB****ATTENTION!**

To avoid fingerprints and damages, always wear (white) cotton gloves when handling the panels.

Make sure that:

- Cut-outs in the panels for spots and other installations are made before installing the panels.
- Panels do have a "direction". Please maintain the mutual orientation from the packing.