



ARCHITECTURAL SHADING DESIGN

Guthrie Douglas

From the beginning, bespoke design has been part of our DNA – in fact, it's where the business started.

Back in 1981, our founder Richard Guthrie accepted the challenge to shade a 60ft long curved and sloping airport façade with a single piece of fabric. Our approach was, and still is, to be responsive to our customers' needs and vision.

Every project is unique, so we start by understanding the problems architects are trying to solve, and often bring ideas to the table that may not have been considered before. We draw upon our teams' expertise in engineering, design,

and building physics to create shading systems that work seamlessly with their surroundings, harnessing the power of light and shade as positive architectural features, rather than restrictions or problems to be overcome later.

We collaborate with designers who share our love of inspirational and sustainable architecture, and love nothing more than getting involved where engineering and design challenges are yet to be resolved.

FROM DESIGN

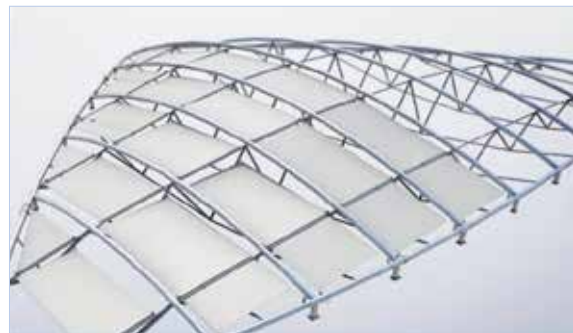

TO REALITY

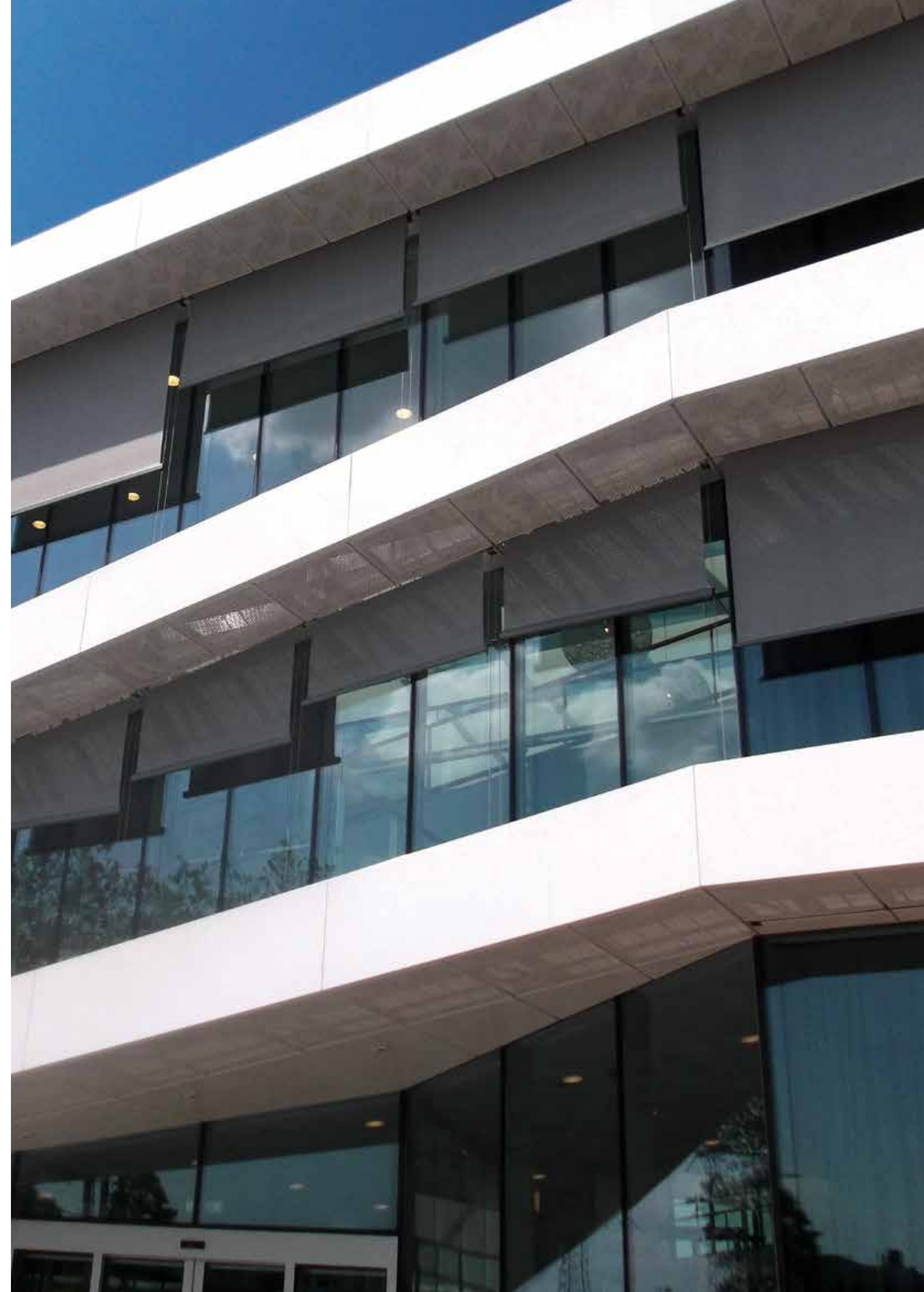

OUR SERVICES

Service and maintenance training

Design brief/problem diagnosis

Building physics modelling

Shading system design and specification

Concept testing

Building integration and control

Client proposal

System demonstration/mock up

Manufacture, assembly and testing

Installation, commissioning and user training

PRODUCT OVERVIEW

TESS™ systems are distributed and installed through our worldwide network of partners, giving you the freedom to choose from a wide range of fabrics and control systems.

Our in-house engineering team can design special components for projects requiring bespoke solutions.

For more information and guidance on fabric selection, visit www.guthriedouglas.com

SERIES	SIZE	PRODUCT	INTERNAL	EXTERNAL	TYPE SHAPE	GUIDES	APPLICATION
TESS 600 Compact design for smaller windows and blackout	<13m ²	TESS 640	●	●	■	ROD	
		TESS 660	●	●	■	SIDELOCK	
		TESS 600	●	●	■	—	
		TESS 601	●		▲	—	
		TESS 602	●		▲	—	
TESS 100 Versatile internal range without headbox for flat, curved or triangular glazing	<18m ²	TESS 140	●	●	■	WIRE	
		TESS 120	●		■	RAIL	
		TESS 100	●		⤿	—	
		TESS 101	●		▲	—	
		TESS 102	●		▲	—	
TESS 400 Versatile external range with headbox for flat, curved or triangular glazing	<16m ²	TESS 440		●	■	WIRE	
		TESS 420		●	■	RAIL	
		TESS 400		●	⤿	—	
		TESS 401		●	▲	—	
		TESS 402		●	▲	—	
TESS 200 Strong twin-barrel system for large applications	<60m ²	TESS 200	●		⤿	—	
TESS 300 Robust drop down blinds for large applications	<72m ²	TESS 308/312	●		■	WIRE	
TESS 500 Large horizontal pergola system	<100m ²	TESS 512	●	●	■	WIRE	

TESS™ TENSIONED SOLAR SHADING SYSTEMS

TESS™ systems are built around a unique single barrel tension mechanism which makes them strong and capable of shading very large spaces regardless of shape or inclination. Motor, spring, gearbox and control cable work in harmony to consistently hold fabric flat and intelligently adapt to the surrounding environment, regardless of angle or system direction.

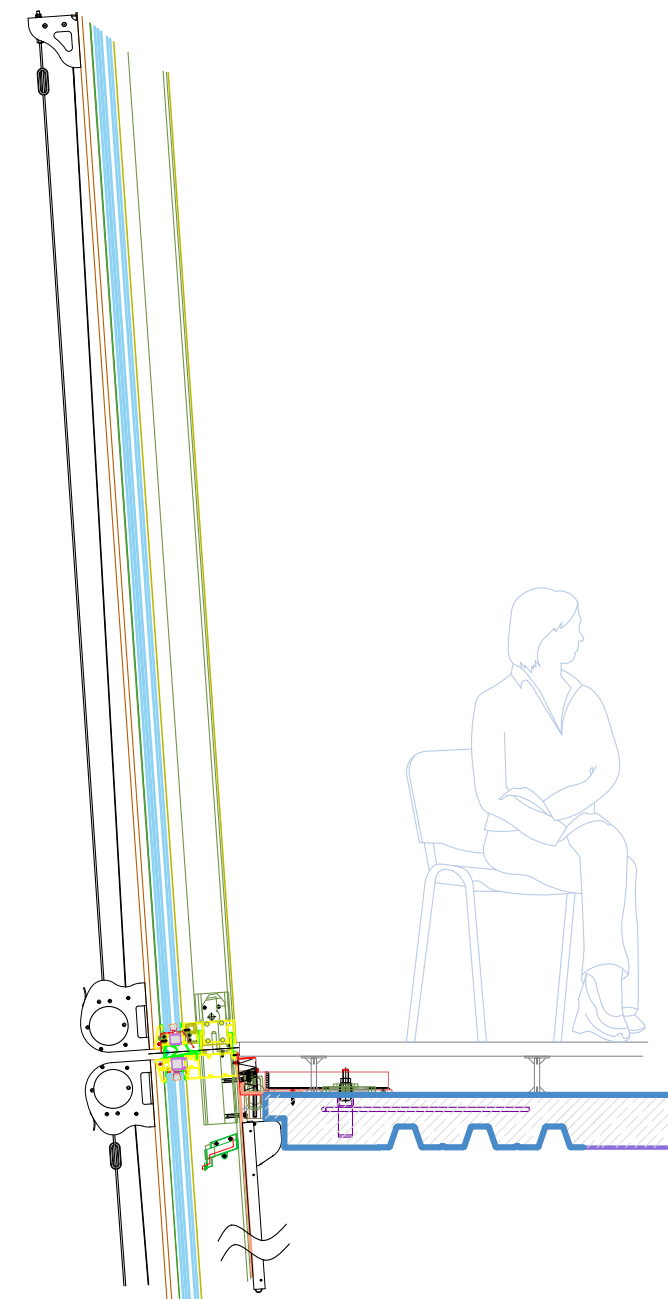
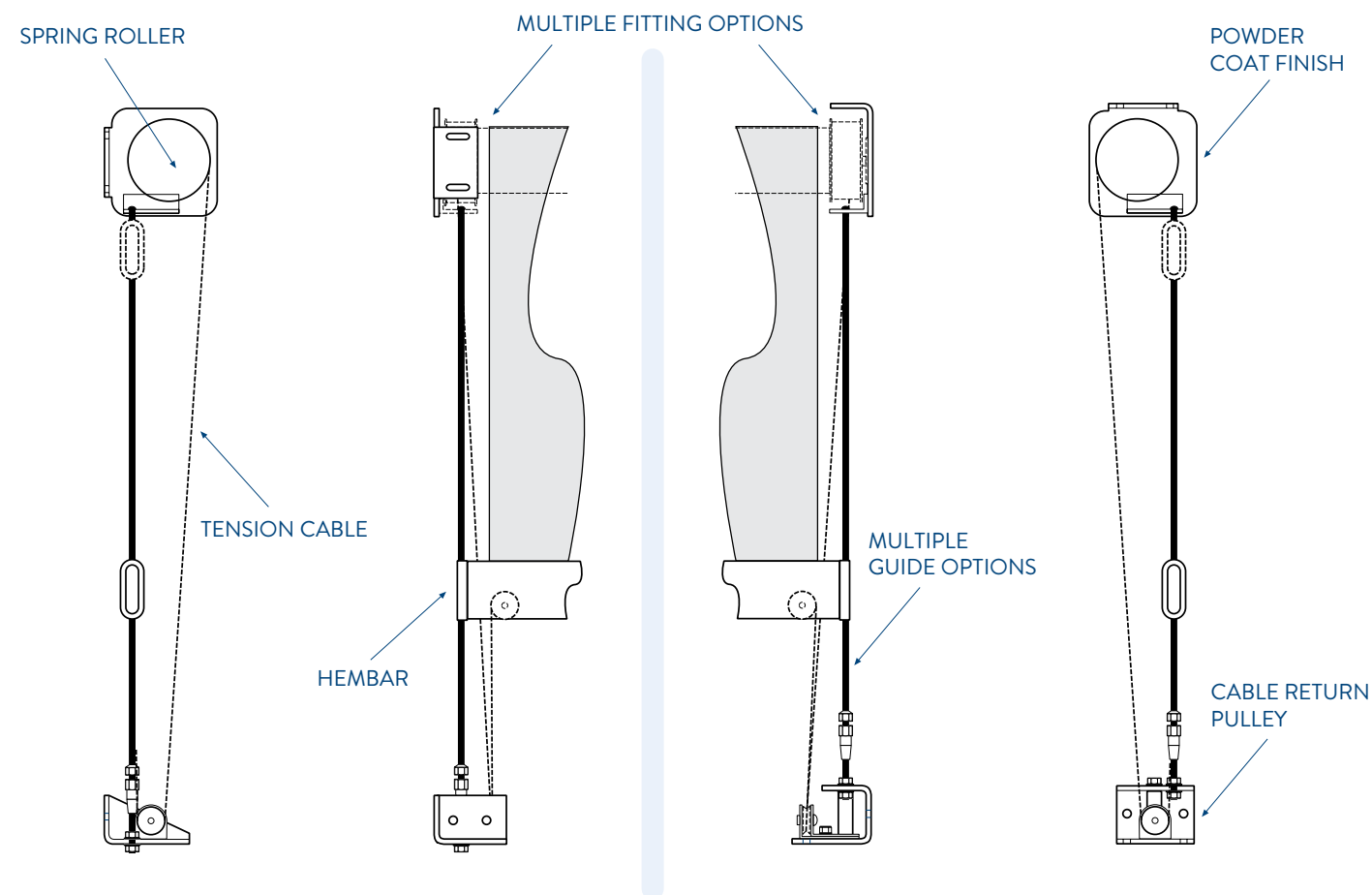



STANDARD CONFIGURATION OPTIONS

Tensioned façade blinds can be integrated within the curtain wall or façade structure for a clean look, or can be set out from the façade using stainless steel cable guides to create the illusion of floating fabric. Of course, every project comes with its own challenges, so here we've set out some of the most commonly used configurations.

DESCRIPTION	TOP-DOWN	BOTTOM UP	ANY ANGLE	CURVED	SHAPED	SIDeways	DUO SCREEN	DOUBLE SCREEN
FABRIC LAYERS	1	1	1	1	1	1	2	2
MOTORS	1	1	1	1	1	1	2	2
FABRIC TYPE	ANY	SCREEN	SCREEN	SCREEN	SCREEN	SCREEN	ANY	SCREEN
DIFFICULTY	LOW	LOW	MEDIUM	HIGH	HIGH	MEDIUM	LOW	MEDIUM

RELIABILITY THAT'S PROVEN



If you're considering an automated shading system you may be concerned that despite the benefits, moving parts can mean added project risk and unwanted maintenance. That's why we're determined that our products deliver both elegance and efficiency, without inconvenience. The tension mechanism at the core of our technology is precise, yet deceptively simple, and doesn't rely on delicate

dual motor balancing arrangements or complex gas strut devices. Our systems are tested in our factory for many tens of thousands of cycles – well in excess of 4 times their normal usable life. All our products are designed and built in the UK from European components, to meticulous quality standards, so you can be sure they won't just look good, they'll work, and keep working.

VERSATILITY FROM ALL ANGLES

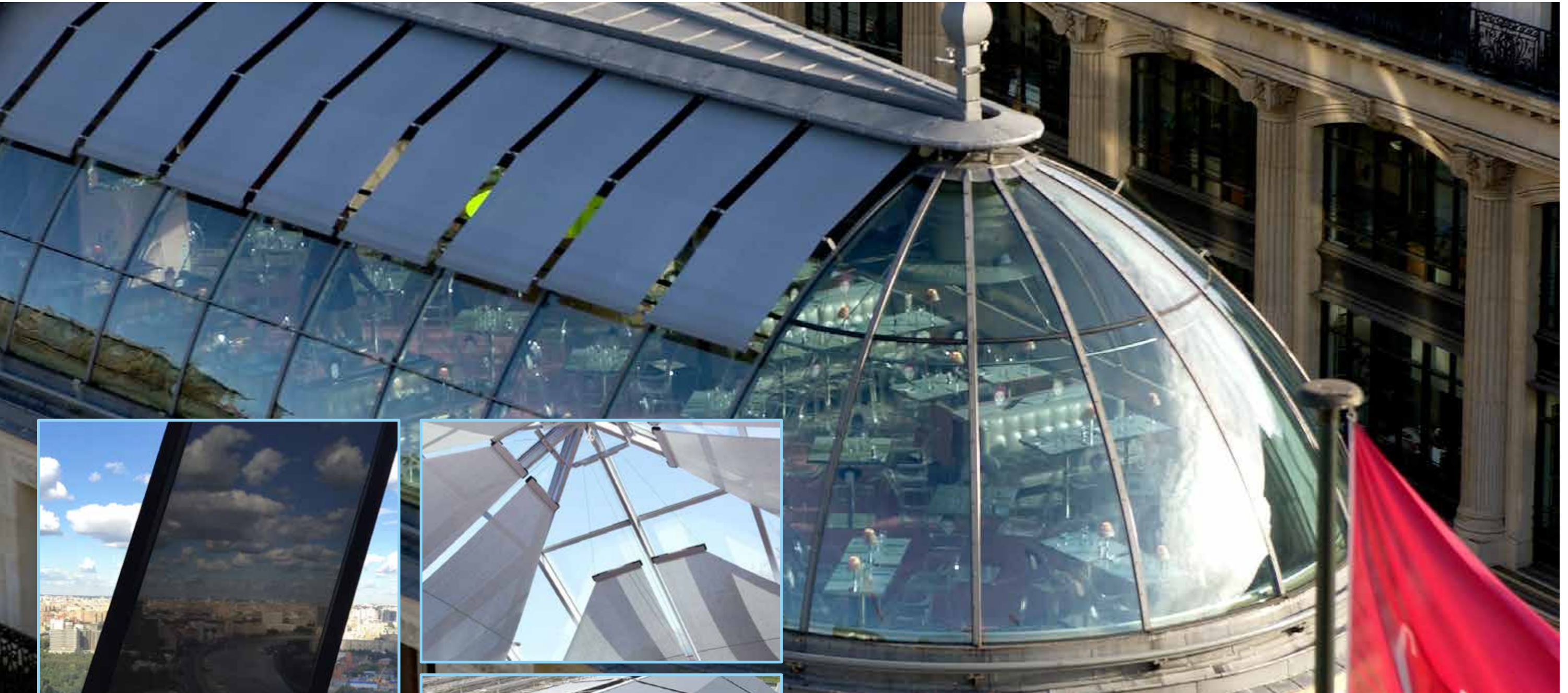

Over 35 years spent developing products and bespoke projects means we've built up a substantial library of creative ideas for façades of all shapes, angles, sizes and configurations. A variety of 'off-the-shelf' guide systems and adaptable brackets

mean we can work with any structure to ensure invisibility when the blind is retracted, and our unlimited colour finishes and a wide range of technical fabrics give you the freedom to configure the product to your project brief.

The interaction of light with a glass surface is a complex area of study, and one we're constantly examining. Advanced building physics modelling systems can simulate the effect of solar radiation and energy flows on internal environments, examining variables such as solar angle (dependent on geographic location and time of year), glazing type, shading system, and the aspect and construction of a specific building.

SOLAR ENERGY CONTROL

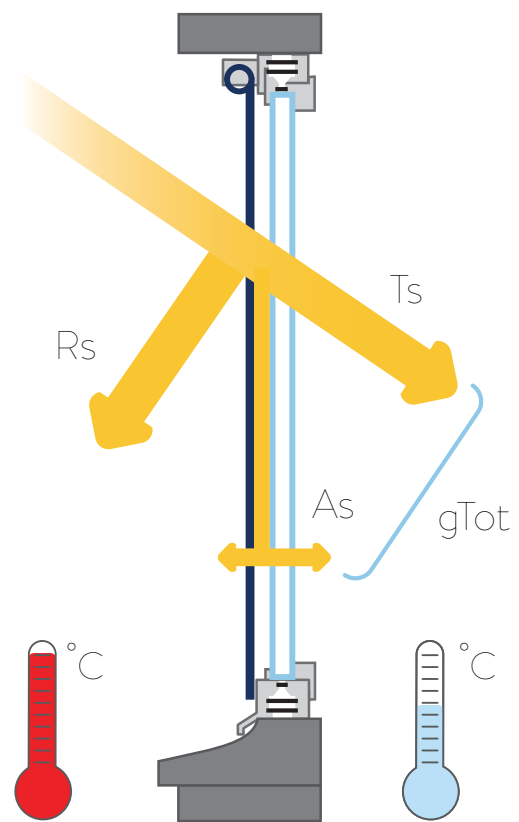

THERMAL GAIN

The g-value, or total solar energy transmittance, is the percentage of solar energy that reaches the interior of a building. It is calculated from a number of factors, including direct transmittance, reflectance, and absorptance.

Fabric shading can achieve a g-value as low as 0.02 for all types of glazing. This means that fabric shading can deliver the required environmental benefits while also reducing the overall project cost, as savings can be made on the glazing specification.

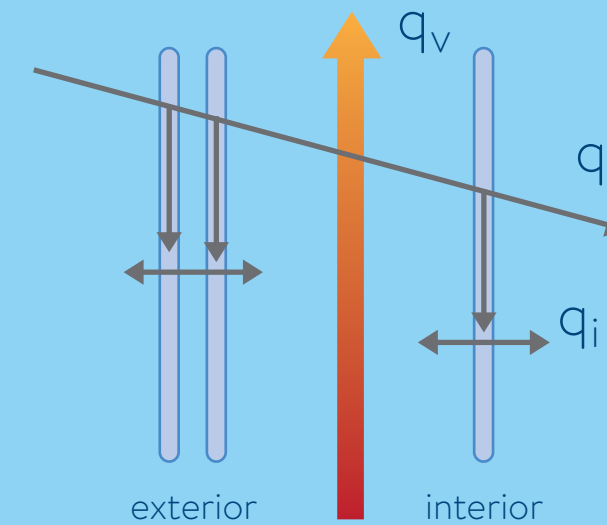

ENERGY SAVINGS

Dynamic fabric shading can mean significant energy savings because it removes the need for artificial cooling, lighting and heating. For south facing facades this reduction can even be as much as 65%.

The biggest single area of savings is air conditioning, where external blinds can help achieve energy savings of over 70%. (Source: ESSO). Savings are also significant for lighting costs, especially where building management systems synchronize shading and lighting use.

Whereas louvers, film or 'solar control' glazing cast a permanent shadow, automated fabric shades offer more versatile control and allow you to enjoy natural light, even in duller conditions. Finally, the use of highly insulating fabrics can even reduce heating costs in colder weather, especially when closed overnight.

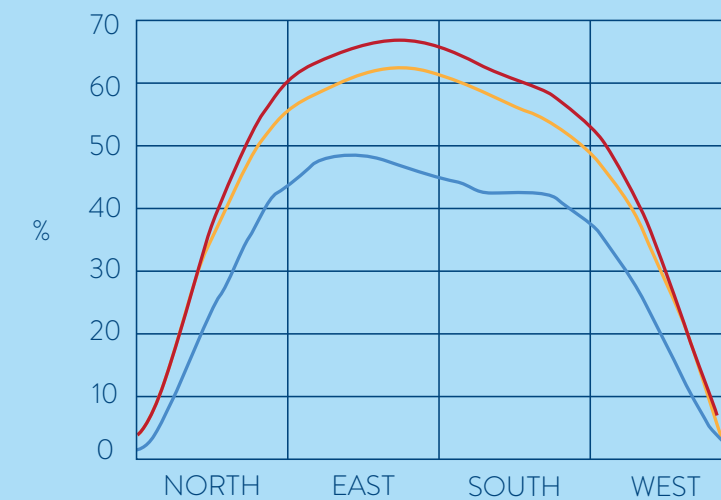

Reduction in primary energy use for heating, cooling and lighting through shading, when compared to the energy use without shading, for double glazing (red), low-e glazing (orange), and solar control glazing (blue).

CO² EMISSIONS

If environmental credentials are important to the design brief, fabric shading will make a real difference. The appropriate automated fabric shade will deliver energy savings of up to 60 times its CO² footprint over a 20 year lifespan. Approximately 86% of relevant emissions come from the extraction of raw materials and the production of primary products. Only 0.5% is created during manufacturing. This makes fabric shading a popular choice for any designer thinking about environmental impact.



VISUAL COMFORT

Glare is uncomfortable, distracting and at its worst can make office conditions impossible to work in. Dynamic shading systems regulate brightness, to maximize natural daylight while also reducing glare and contrasts. Tensioned roller systems can operate bottom up or at an angle to control both reflected and direct glare.

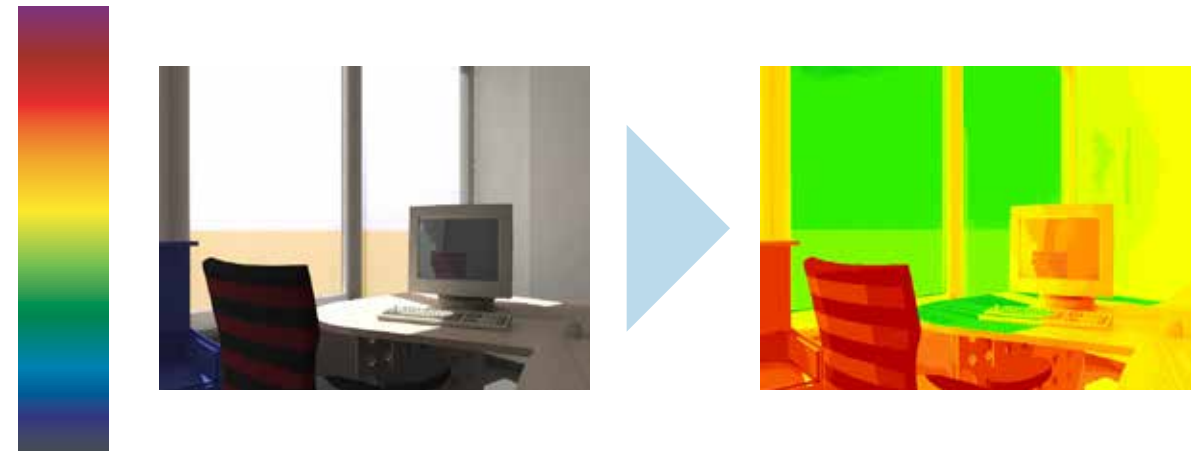

PRODUCTIVITY, HEALTH AND WELLBEING

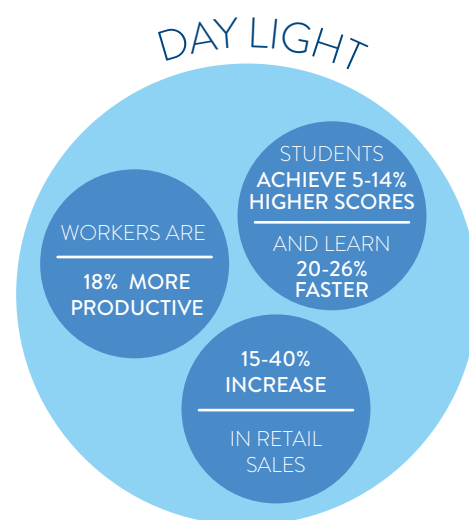
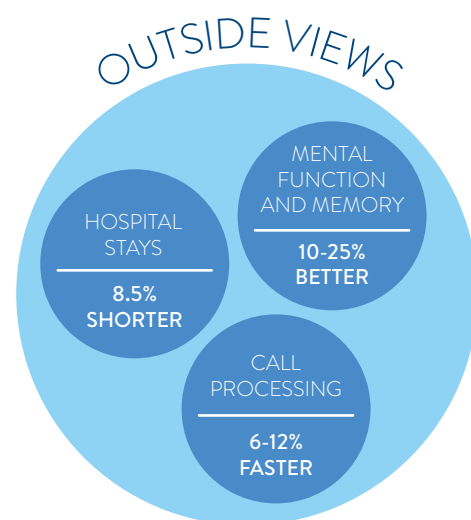

NATURAL DAYLIGHT & VIEWS TO THE OUTDOORS

In just 50 years, we have moved from spending 90% of our waking hours outside, to spending 90% inside.

World Green Building Council research has proven the dramatic impact that natural daylight and views to the outdoors have on human behaviour and productivity. A connection to the outdoors makes us healthier, helps us work better, and makes us happier. Dynamic shading combined with clear glazing is recommended as the most effective way to achieve low g-values without compromising the quality of light that enters the building.



WWW.GUTHRIEDOUGLAS.COM